

Schlüter®-VINPRO-U

Finishing profile for resilient coverings
for stepless transitions

18.3

Product data sheet

Application and function

Schlüter-VINPRO-U is a special finishing profile made of anodised aluminium for creating stepless transitions from resilient floor coverings (e.g. LVT flooring) to adjoining coverings of a lower height. VINPRO-U features a bevelled visible area to eliminate trip edges between coverings of different heights. In addition, the profile reliably protects the edges of resilient coverings.

Material

Schlüter-VINPRO-U is available in the following materials:

ACGB = Brushed chrome anodised aluminium

ATGB = Brushed titanium anodised aluminium (colour may differ from other Schlüter profiles in ATGB finish)

ABGB = Brushed antique bronze anodised aluminium

Material properties and areas of application:

In applications exposed to chemical or mechanical stresses, the profile's suitability must be verified.

The information provided below is intended as a general guideline.

Anodised aluminium: The aluminium features an anodised finish that may be damaged by aggressive substances or abrasive stresses. Damage to the anodised surface can be restored with paint.

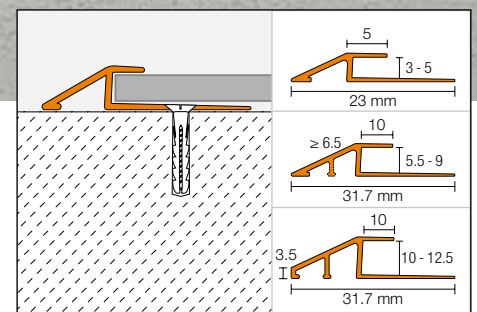



Installation

Attachment with screws:

1. Select Schlüter-VINPRO-U according to the thickness of the covering.
2. Transfer the positions of the drill holes to the substrate at the edges of the covering and drill holes with a diameter of 5 mm for the screw anchors.
3. Attach the profile to the floor with counter-sunk screws, Ø 3.5 mm.
4. Follow the manufacturer's specifications for installing the covering.

Attachment with installation adhesive:

1. Select Schlüter-VINPRO-U according to the thickness of the covering.
2. Adhere the profile with the installation adhesive Schlüter-KERDI-FIX or an equivalent material at the edges of the covering. This installation method is especially suitable for areas where the profile cannot be screwed into the floor.
3. Follow the manufacturer's specifications for installing the covering.

Note: The substrate must be load-bearing and free from debris.

Note

Schlüter-VINPRO-U requires no special maintenance or care. Do not use abrasive cleaning agents on the sensitive surfaces. Damage to the anodised surface can be restored with paint. All cleaning agents must be free of hydrochloric and hydrofluoric acid.

Text template for tenders:

_____ linear metres of Schlüter-VINPRO-U as a special finishing profile made of anodised aluminium for creating stepless transitions from resilient floor coverings (e.g. LVT flooring) to adjoining coverings of a lower height, to be supplied and professionally installed according to manufacturer's specifications.

Material:

■ ACGB = Brushed chrome anodised aluminium

■ ATGB = Brushed titanium anodised aluminium

■ ABGB = Brushed antique bronze anodised aluminium

Height of profile channel H = _____ mm

Art.-No.: _____

Material: _____/m

Labour: _____/m

Total: _____/m

Product overview:

Schlüter®-VINPRO-U

ACGB = brushed chrome anodised aluminium / ATGB = brushed titanium anodised aluminium / ABGB = brushed antique bronze anodised aluminium

Length supplied: 2.50 m

H = mm	3	4	5	5.5	6	6,5	7	7.5	8	8.5	9	10	11	12.5
ACGB	•	•	•	•	•	•	•	•	•	•	•	•	•	•
ATGB	•	•	•	•	•	•	•	•	•	•	•	•	•	•
ABGB	•	•	•	•	•	•	•	•	•	•	•	•	•	•