

# Schlüter®-KERDI-LINE-VARIO

## Drainage

Variable linear drains for bonded waterproofing assemblies

# 8.10

Product data sheet

### Application and function

Schlüter-KERDI-LINE-VARIO is a flexible, multi-piece, linear drainage system for creating floor level showers with ceramic tiles or natural stone.

The two-piece horizontal KERDI-LINE-VARIO drain unit comprises a drain body and a drain adapter. The drain body consists of an ultra slim, wave-shaped drain that is rotatable by 360° and a built-in odour trap. The wave-shaped design achieves a high flow rate within the floor drain, which results in a self cleaning effect.

The sound insulation component included in the set reliably prevents specific sound transmission of the drain body to the surrounding wall or floor structures and serves as a positioning aid for direct installation in a wall.

To guarantee an especially low assembly height, the drain adapter of KERDI-LINE-VARIO H40 with integrated Schlüter-KERDI-FLEX collar comes fully inserted into the sealed wave-shaped drain and is secured with a clamping ring. The wave-shaped drain can be rotated by 360° when the clamping ring is released, which makes the drainage system adaptable to any connection configuration in the existing building. The drain adapter of KERDI-LINE H50 can be individually cut to size to match the structural requirements on site.

Two design drainage profiles are available for KERDI-LINE-VARIO. These can be individually cut to size, are height adjustable and are shipped with 2 matching end caps.

**Schlüter-KERDI-LINE-VARIO COVE** is a cove-shaped drainage profile that can be flexibly cut to size. It features a visible 8 mm wide drainage opening in a length of 140 mm. It is available in brushed stainless steel V4A or powder coated aluminium with

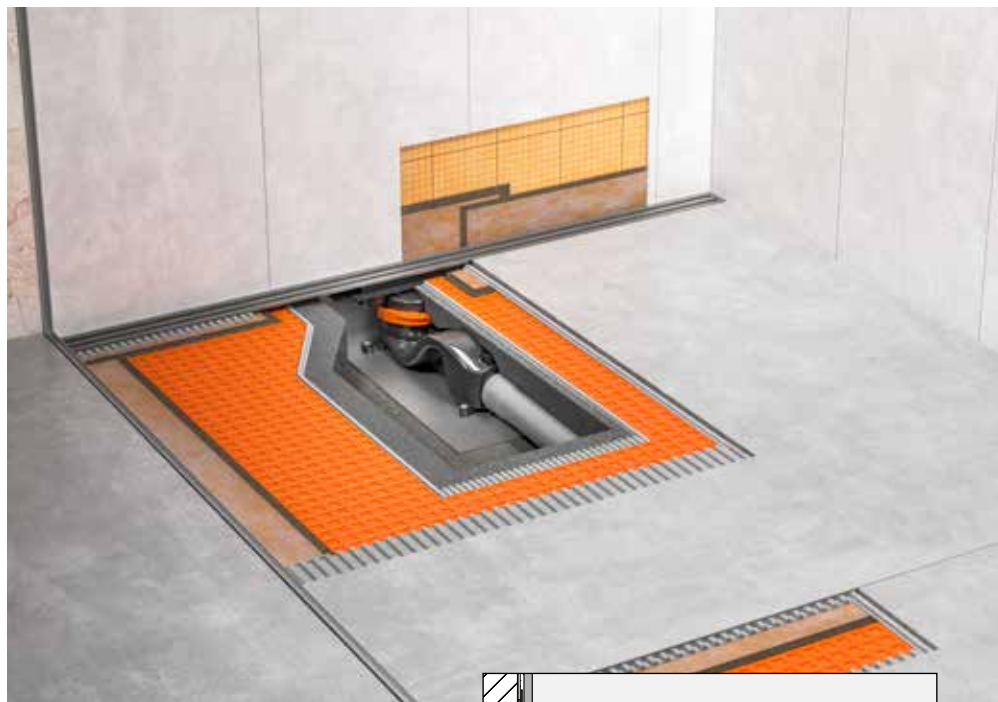

a textured TRENDLINE finish and can be ordered in lengths of 120 cm and 180 cm.

**Schlüter-KERDI-LINE-VARIO WAVE** is a W-shaped drainage profile, which can be individually cut to size. It is also available in brushed stainless steel V4A or powder coated aluminium with a textured TRENDLINE finish and can be ordered in lengths of 120 cm and 180 cm.

The aluminium version is available in two profile widths, 34 mm and 42 mm. In the narrower version, the drain opening in the centre is only 14 mm wide and 140 mm long. The drain opening of the 42 mm wide version is 24 mm wide and 140 mm long, which offers sufficient space for inserting an optionally available hair trap.

The stainless steel version with a profile width of 42 mm features a drain opening

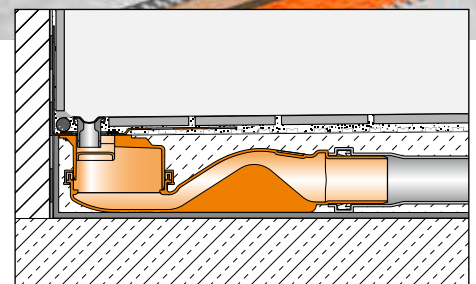

Schlüter-KERDI-LINE H40 with Schlüter-KERDI-LINE-VARIO COVE 26 cover

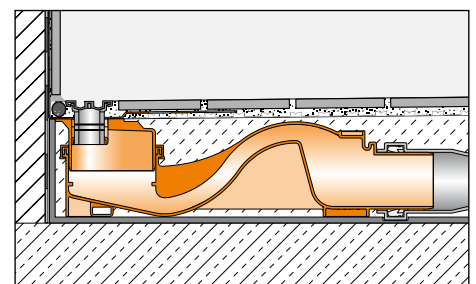

Schlüter-KERDI-LINE H50 with Schlüter-KERDI-LINE-VARIO WAVE 42 cover



that is 25 mm wide and 140 mm long. It also has sufficient space for inserting an optionally available hair trap. All profile versions of KERDI-LINE-VARIO WAVE feature a visible drain opening which can be concealed from view with a removable panel. Please refer to page 7 for the corresponding drawings.

The pre-adhered elasticated KERDI collar integrated into the drain adapter ensures the reliable connection of the drain body to the bonded waterproofing assembly, both in the floor area and on upright walls. It is securely covered by a transparent protective lid. In conjunction with the waterproofing systems Schlüter-KERDI, Schlüter-DITRA, Schlüter-DITRA-HEAT or Schlüter-KERDI-BOARD and the matching system adhesives Schlüter-KERDI-COLL-L or Schlüter-KERDI-FIX, installers can create certified bonded waterproofing assemblies with connecting linear drainage. KERDI-LINE is a system component that complies with the German waterproofing standard DIN 18534. Together with the above-listed Schlüter-Systems it has general technical approval (abP) in Germany.

Please refer to the respective product data sheets for information about the moisture exposure classes according to abP. Schlüter-KERDI-LINE is a system component with European Technical Assessment (ETA) according to ETAG 022 (watertight covering kits). Schlüter products tested together with KERDI-LINE bear the CE mark.

**Note:**

Due to the variable drain construction, KERDI-LINE-VARIO requires the installation of a sloped screed. The surface of the screed must be waterproofed with DITRA (see product data sheet 6.1) or DITRA-HEAT (see product data sheet 6.4). Schlüter-SHOWERPROFILE-S and -R (see product data sheet 14.1) are supplementary components for creating a floor or wall connection. SHOWERPROFILE-S has a triangular design to conceal the sloped lateral edges of floor level showers. Waterproof the surrounding walls with KERDI (see product data sheet 8.1) or create a bonded waterproofing assembly with KERDI-BOARD (see product data sheet 12.1).

**Material**

The KERDI-LINE-VARIO WAVE drainage profile is made of anodised aluminium with a textured powder coating or of brushed stainless steel (material no. 1.4404 = AISI 316L).

Schlüter-KERDI-LINE-VARIO COVE is made of anodised aluminium with a textured powder coating or of brushed stainless steel (material no. 1.4404 = AISI 316L).

The wave shaped drain and drain adapter are made of high impact resistant polypropylene (PP).

The KERDI waterproofing collar that is pre-adhered at the drain adapter for connecting to the bonded waterproofing assembly (see product data sheet 8.1) is made of a polyethylene membrane.

The clamping ring at the wave shaped drain is made from coloured polyvinyl chloride (PVC).

The protective lid is made of transparent acrylonitrile butadiene styrene (ABS).

**Material properties and areas of application:**

KERDI-LINE-VARIO drainage systems are classified as K3 according to DIN EN 1253, Gullies for buildings. This class refers to areas without vehicle traffic. Apart from the aluminium version of the WAVE profile, all drainage profiles are able to withstand wheelchair use.

Schlüter-KERDI-LINE-VARIO drainage profiles are available in a wide variety of materials and finishes. Their suitability must be verified in applications exposed to chemical or mechanical stresses. The information provided below is intended as a general guideline.

The drainage profiles COVE and WAVE in the brushed stainless steel V4A version (material no. 1.4404 = AISI 316L) are particularly well suited for applications that, in addition to heavy mechanical stresses, require resistance to chemicals such as acidic or alkaline media and detergents. Their application areas include bathrooms in apartments, nursing homes, hotels and schools as well as public washroom and shower facilities. Even stainless steel is not resistant to all chemical stresses, and may be affected by e.g. hydrochloric and hydrofluoric acid or certain chloride and brine concentrations. In certain cases, this also applies to salt water pools. Special

anticipated stresses should therefore be verified in advance.

The COVE and WAVE drainage profiles made of aluminium (textured coated aluminium) feature surfaces with a natural appearance. The aluminium is pre-treated (anodised) and powder-coated with a polyurethane covering. The colour-stable coating is UV and weather-resistant. Their application areas include bathrooms in apartments, nursing homes or hotels. Visible edges should be protected against abrasion.

**Notes**

The set includes special cleaning brushes with instructions for simple periodic cleaning of the drainage channel and the drain area. All cleaning agents must be free of hydrochloric and hydrofluoric acid. Avoid contact with other metals, such as regular steel, to prevent corrosion.

This also includes installation tools such as trowels or steel wool, e.g. for the removal of mortar residue. Do not use abrasive cleaning agents on the sensitive surfaces. We recommend the use of the stainless steel cleaning polish Schlüter-CLEAN-CP.



Schlüter cleaning brushes for KERDI-LINE-VARIO

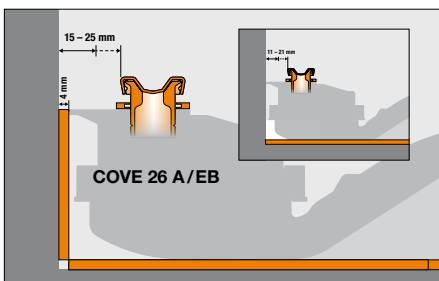
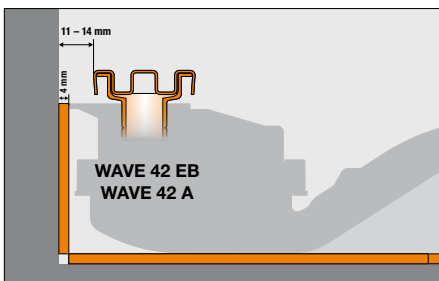
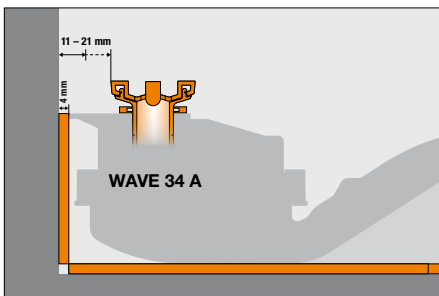
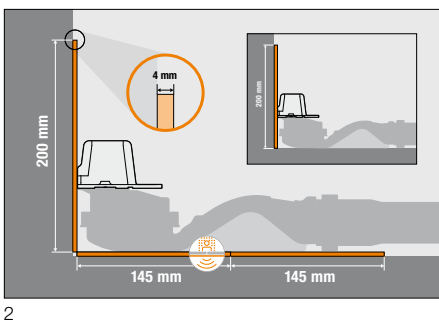
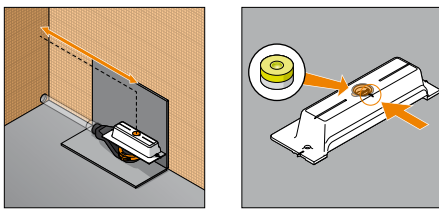
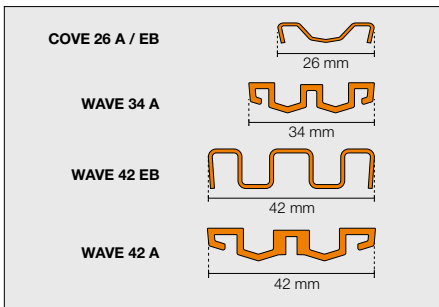

### Installation of KERDI-LINE H40

1. Position the KERDI-LINE-VARIO H40 drain body and adapter in the centre of the weight-bearing structure or over the supplied 4 mm sound insulation component (over a suitable impact sound insulation layer if necessary; see section on soundproofing for further details) (1). Note the materials label on the protective lid (1a). For optimum alignment, insert the supplied spirit level in the corresponding groove of the protective lid.
2. For direct installation (2) at the wall, position the drain body with the profile connector and the protective lid immediately in front of the adjacent wall, using the 4 mm sound insulation component included in the set. This establishes a defined distance of 11 mm from the adjacent wall (not including the wall covering) when the WAVE profile is used (2a+b). In the case of COVE profiles (2c), this results in a distance of 15 mm from the wall in combination with the sound insulation component. To achieve a distance of only 11 mm from the wall, the sound insulation component should be omitted in the wall area when using COVE profiles (2c). Alternatively, the difference can be offset with suitable material, e.g. 5 mm Schlüter-KERDI-BOARD.
3. For connection to the drainage pipe, use the supplied Allen key to open the clamping ring (3) and align the drain body to match the site's structural layout (3a).
4. Then check the adapter is still fully inserted (4) and re-tighten the clamping ring.
5. Recheck the desired positioning after connecting the assembly to the drain pipe. In case of uneven surfaces or for height adjustment, you can also precisely position the drain body on a levelling layer (5).
6. Perform a leak test (6).
7. Install the sloped screed (2%) of the shower floor area to create a weight bearing assembly that completely encompasses the drain body (7). Use the screw-attached protective lid to aid with alignment and levelling. It must be flush with the top surface of the screed (7a).

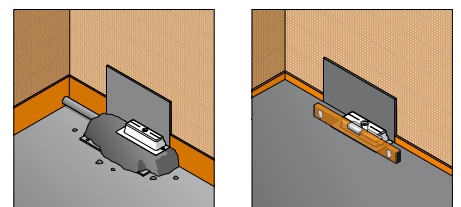
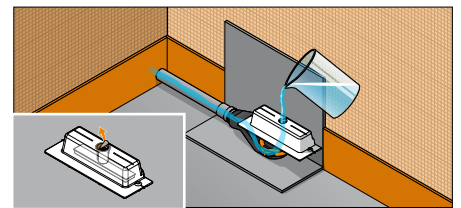
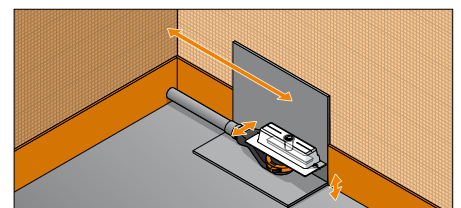
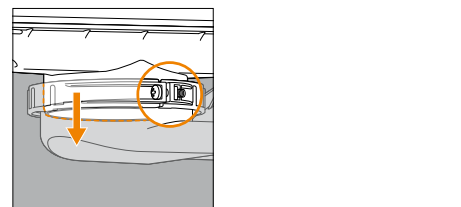
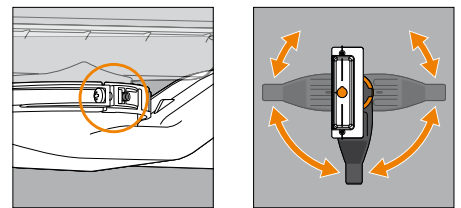
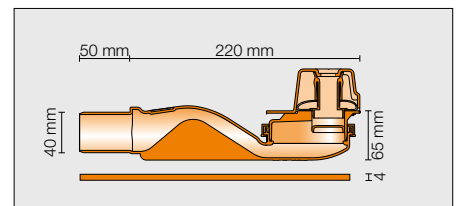

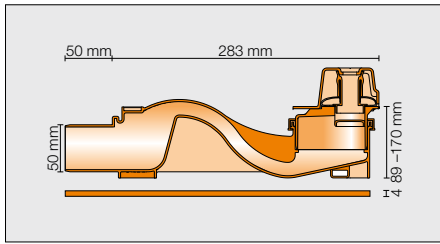

### Installation of KERDI-LINE H50

1. Position the KERDI-LINE-VARIO H50 drain body and adapter on the weight-bearing structure or over the supplied 4 mm sound insulation component (over a suitable impact sound insulation layer if necessary; see section on soundproofing for further details) (1). Note the materials label on the protective lid (1a). For optimum alignment, insert the supplied spirit level into the corresponding groove of the drain body. Cut the drain adapter to match the height of the floor assembly and carefully de-burr the edges (1b), then open the clamping ring and insert the adapter into the drain body, using the supplied lubricant (1c).  
Note: To allow for height adjustment of coverings with insulation, cut the drain adapter in such a way that does not directly sit on the drain body (1d).

2. For direct installation at the wall, position the drain body with the profile connector and the protective lid immediately in front of the adjacent wall, using the 4 mm sound insulation component included in the set (2). This establishes a defined distance of 11 mm from the adjacent wall (not including the wall covering) when using Schlüter-WAVE profiles (2a+b).

In the case of Schlüter-COVE profiles, this results in a distance of 15 mm from the wall in combination with the sound insulation component.

To achieve a distance of only 11 mm or less from the wall, the sound insulation component should be omitted when using Schlüter-COVE profiles (2c). Alternatively, the difference can be offset with suitable material, e.g. 5 mm Schlüter-KERDI-BOARD.

3. For connection to the drainage pipe, align the drain body to match the site's structural layout (3).

4. Check the fit between the adapter and drain body and re-tighten the clamping ring (4).
5. Recheck the desired positioning after connecting the assembly to the drain pipe. In case of uneven surfaces or for height adjustment, you can also precisely position the drain body on a levelling layer. The supplied attachment set enables optional fixed attachment to the supporting structure (5b).
6. Perform a leak test.
7. Remove the spirit level from the drain body prior to installing the screed. Then install the sloped screed (2%) of the shower floor area to create a weight bearing assembly that completely encompasses the drain body (7). Use the screw attached protective lid to aid with alignment and levelling. It must be flush with the top surface of the screed. (7a)

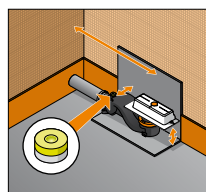

1

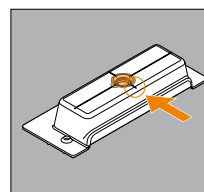

1a

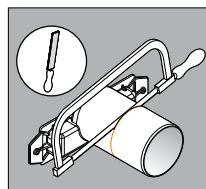

1b

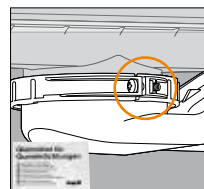

1c

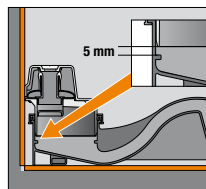

1d

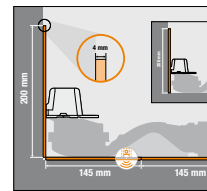

2

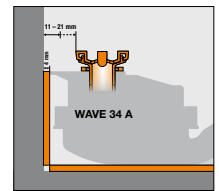

2a

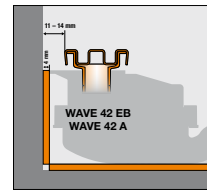

2b

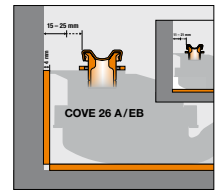

2c

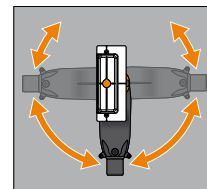

3

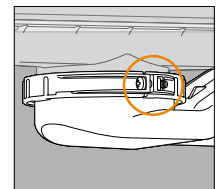

4

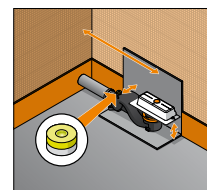

5

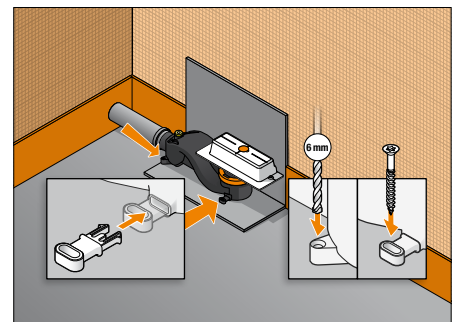

5a

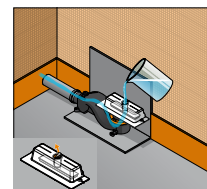

6

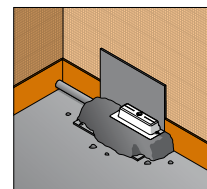

7

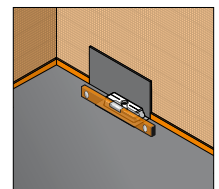

7a





## Uncoupling and waterproofing

8. Remove the protective lid once the screed surface is ready to bear weight (8). Apply thin-bed tile adhesive to amend any flaws in the screed (8a).
9. Now use thin-bed tile adhesive to firmly adhere DITRA (recommended notched trowel size: 3 x 3 mm or 4 x 4 mm) or DITRA-HEAT (recommended notched trowel size 6 x 6 mm) to the screed surface (9). Cut the edge insulation strips and the sound insulation component to the proper height (9a). Tiles adhered over DITRA or DITRA-HEAT must have a size of at least 5 x 5 cm. (see also product data sheet 6.1 or 6.4)
10. To attach the KERDI collar, apply the sealing adhesive KERDI-COLL-L (see product data sheet 8.4) to the adjoining waterproofing assembly, using a 3 x 3 or 4 x 4 mm notched trowel (10) and fully embed the KERDI collar in the adhesive (10a). The curing time of the adhesive must be observed.
11. Create and tightly seal the wall connections with KERDI-KEBA sealing bands and KERDI-COLL-L (11).
12. Apply covering materials such as tiles or natural stone (12). (Covering thickness must match the selected drainage profile; see page 6, Table 12a)

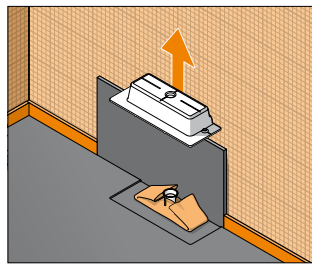

8

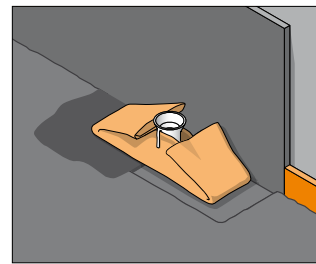

8a

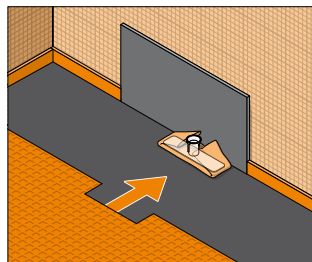

9

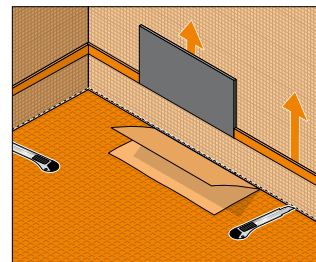

9a

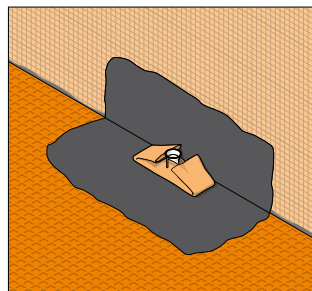

10

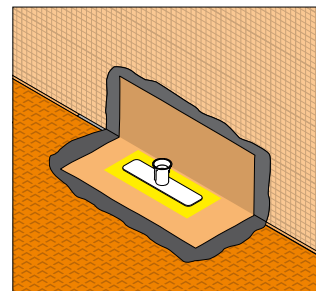

10a

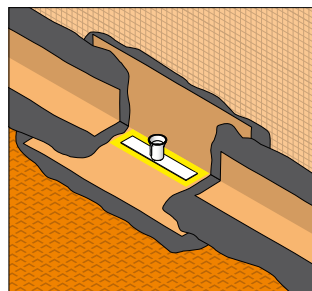

11

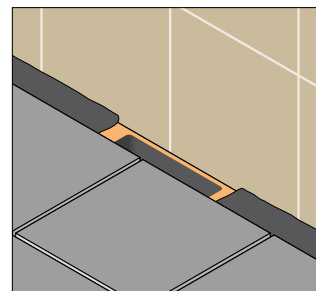

12

## Soundproofing

For soundproofing as specified in DIN 4109, VDI 4100, ÖNORM B 8115-2 or SIA 181, the Schlüter-KERDI-LINE-SR sound insulation panel complies with impact sound, installation noise and user noise limits in certified assembly variants of KERDI-LINE-VARIO. Please refer to our Planning Tool for further details.

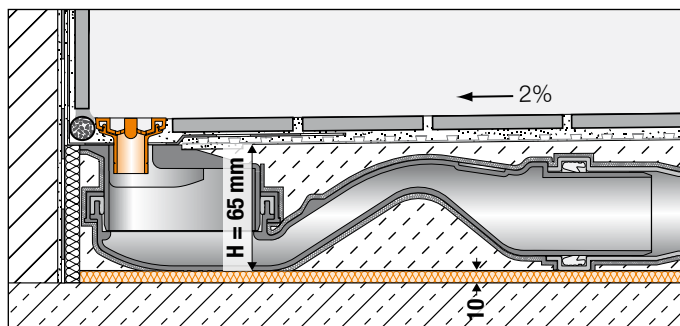

Shower area with Schlüter®-KERDI-LINE-VARIO  
on Schlüter®-KERDI-LINE-SR

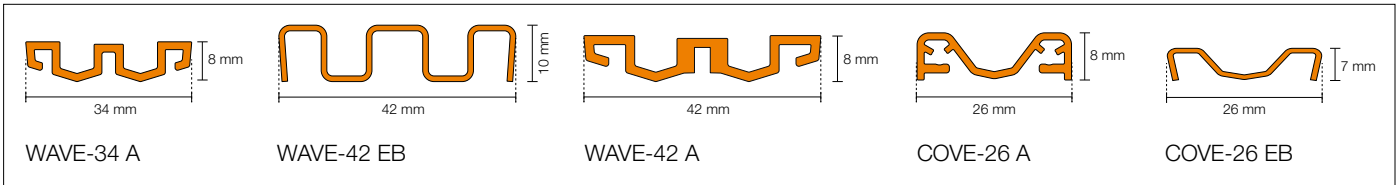

### Installation of drainage profiles

1. Cut the drainage profile to size with a suitable handsaw to match the structural requirements on site, using the supplied cutting gauge (do not use an angle cutter) (1) and de-burr the cut (1a).
2. The set includes two end caps to create a simple and elegant finish (2a/2b/2c).
3. The aluminium profiles COVE 26 and WAVE 34 come with a cover frame, which is fitted precisely over the drain adapter in advance, using thin-bed tile adhesive (3).
4. Adjust the height of the drainage profile by filling with thin-bed tile adhesive (4) in such a way that it is flush with or just slightly below the covering surface. For optimum load transfer, make sure to avoid all cavities when embedding the drainage profile with mortar, particularly in the area of the drain opening.

**Note:**  
 KERDI-LINE-VARIO can also be installed in suspended timber floor substrates. Please contact us for further details.  
 KERDI-LINE-VARIO drainage profiles are intended for positioning in the wall and intermediate floor areas and should not be installed near the entry of the shower area. Please contact our Technical Department with any questions you may have.

Article	Covering thickness (d)	with extension	Installation type
COVE-26 A	6 – 15 mm*	15 – 25 mm*	VR DSE 14
COVE-26 EB	6 – 15 mm*	15 – 25 mm*	VR DSE 14
WAVE-34 A	6 – 15 mm*	15 – 25 mm*	VR DSE 14
WAVE-42 EB	8 – 18 mm*	18 – 28 mm*	VR DSE 23
WAVE-42 A	8 – 18 mm*	18 – 28 mm*	VR DSE 23

\* 3 mm if using DITRA-HEAT-DUO

12a

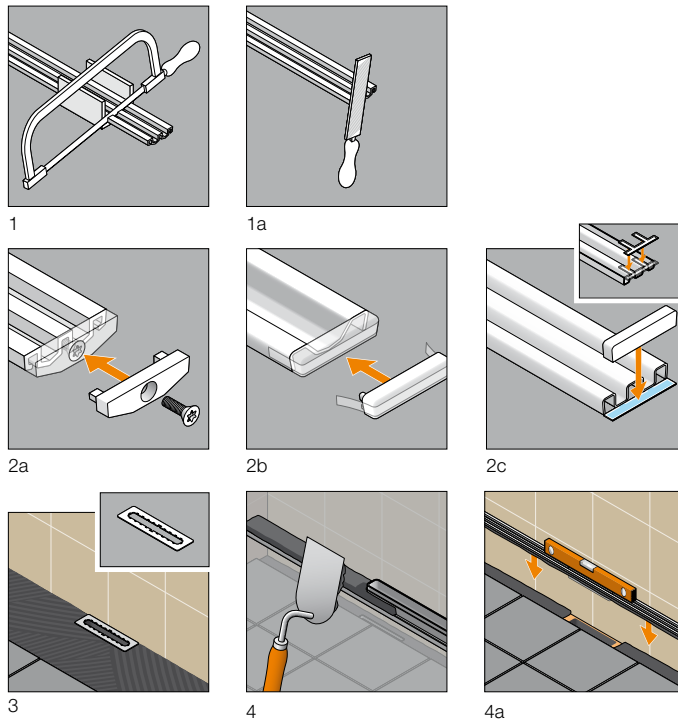



### Schlüter®-KERDI-LINE-VARIO-H40

Horizontal drain with built-in odour trap within the drain body

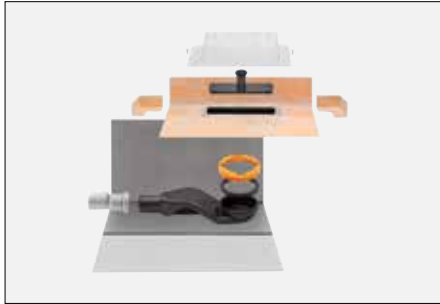

Drain capacity according to DIN EN 1253:

With drainage profile

COVE 26 and WAVE 34

for 2 cm accumulation height =

0.45 l/s (27 l/min)

for 1.5 cm accumulation height =

0.40 l/s (24 l/min)

for 0.5 - 1 cm accumulation height =

0.35 l/s (21 l/min)

With drainage profile

WAVE 42

for 2 cm accumulation height =

0.50 l/s (30 l/min)

for 1.5 cm accumulation height =

0.45 l/s (27 l/min)

for 0.5 - 1 cm accumulation height =

0.4 l/s (24 l/min)

### Schlüter®-KERDI-LINE-VARIO

Drainage profiles with end caps, customisable powder-coated or brushed stainless steel

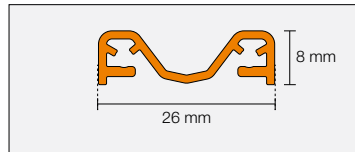

Schlüter®-KERDI-LINE-VARIO-COVE 26 A

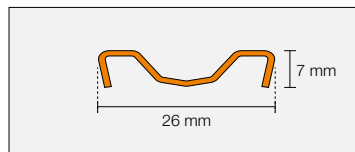
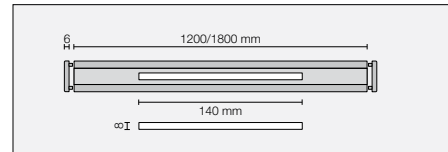

Schlüter®-KERDI-LINE-VARIO-COVE 26 EB

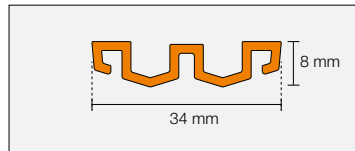
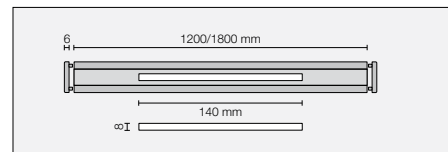

Schlüter®-KERDI-LINE-VARIO-WAVE 34 A

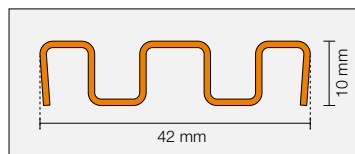
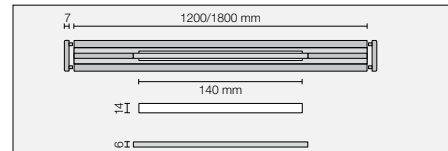

Schlüter®-KERDI-LINE-VARIO-WAVE-42 EB

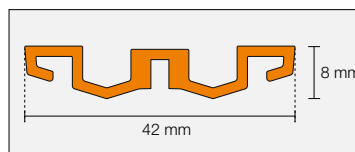
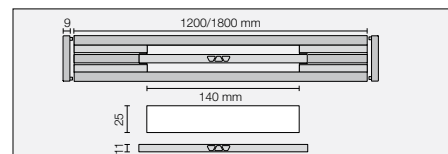

Schlüter®-KERDI-LINE-VARIO-WAVE 42 A

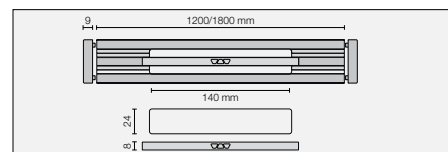

These drainage profiles in aluminium are powder-coated and can be supplied in the following finishes and colours:

MBW = matte brilliant white

MGS = matte graphite black

TSBG = textured beige grey

TSC = textured cream

TSDA = textured dark anthracite

TSI = textured ivory

TSOB = textured bronze

TSSG = textured stone grey

TSG = textured grey



**Schlüter®-KERDI-LINE-VARIO H50**  
**Horizontal drain with built-in odour trap**  
**within the drain body**

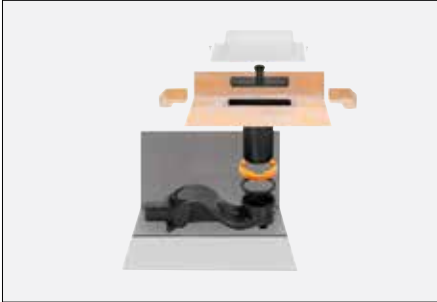

Drain capacity according to DIN EN 1253:

With drainage profile  
COVE 26 and WAVE 34  
for 2 cm accumulation height =  
0.70 l/s (42 l/min)  
for 1.5 cm accumulation height =  
0.65 l/s (39 l/min)  
for 0.5 - 1 cm accumulation height =  
0.60 l/s (36 l/min)

With drainage profile  
WAVE 42  
for 2 cm accumulation height =  
0.80 l/s (48 l/min)  
for 1.5 cm accumulation height =  
0.75 l/s (45 l/min)  
for 0.5 - 1 cm accumulation height =  
0.7 l/s (42 l/min)



**QR code**  
to watch installation video





**Schlüter®-KERDI-LINE-VARIO-DSE 14**  
Frame extension for COVE 26 and WAVE 34 covers for coverings in thicknesses from 15 - 25 mm

Extension Schlüter-KERDI-LINE-VARIO-DSE 14



**Schlüter®-KERDI-LINE-VARIO-DSE 23**  
Frame extension for WAVE 42 cover for coverings in thicknesses from 15 - 25 mm

Extension Schlüter-KERDI-LINE-VARIO-DSE 23



**Schlüter®-KERDI-LINE-VARIO-S 23**  
Hair trap for retrofit installation in WAVE 42

Hair trap for WAVE 42

**Text template for tenders:****Drain body H40:**

\_\_\_\_\_ units Schlüter-KERDI-LINE VARIO H40 G5 as a set for linear floor level showers comprising a pre-attached drain adapter in a fixed length with an integrated elasticated KERDI waterproofing collar and a horizontal, wave-shaped outlet that can be rotated by 360 degrees and includes an integrated odour trap. Incl. sound insulation element and two cleaning brushes. Installation height 65 mm, water trap height 25 mm and pipe connection DN40 for interior installation, to be supplied and installed

- in wall areas
- in the centre of the surface

. . . in a sloped screed according to manufacturer's specifications.

Art.-No.: \_\_\_\_\_

Material: \_\_\_\_\_ £/unit

Labour: \_\_\_\_\_ £/unit

Total: \_\_\_\_\_ £/unit

**Drain body H50:**

\_\_\_\_\_ units Schlüter-KERDI-LINE VARIO H50 G5 as a set for linear floor level showers comprising a drain adapter that can be cut to size to meet on-site requirements with an integrated elasticated KERDI waterproofing collar and a horizontal, wave-shaped outlet that can be rotated by 360 degrees and includes an integrated odour trap. Incl. sound insulation element and two cleaning brushes. Installation height 89 to 170 mm, water trap height 50 mm and pipe connection DN50 for interior installation, to be supplied and installed

■ in wall areas

■ in the centre of the surface

. . . in a sloped screed according to manufacturer's specifications.

Art.-No.: \_\_\_\_\_

Material: \_\_\_\_\_ £/unit

Labour: \_\_\_\_\_ £/unit

Total: \_\_\_\_\_ £/unit

**Drainage profiles**

\_\_\_\_\_ units Schlüter-KERDI-LINE VARIO COVE 26 drainage profile

as a 1.2 m cove-shaped, height-adjustable drainage profile that can be variably cut to size, featuring a visible drain slot in a width of 8 mm and a length of 140 mm, and including 2 end caps, to be installed in the proper height as part of the covering installation.

\_\_\_\_\_ units Schlüter-KERDI-LINE VARIO WAVE 34 drainage profile

as a 1.2 m W-shaped, height-adjustable drainage profile that can be variably cut to size, featuring a visible drain slot in a width of 14 mm and a length of 140 mm that can be concealed from view with a removable panel, and including 2 end caps, to be installed in the proper height as part of the covering installation

\_\_\_\_\_ units Schlüter-KERDI-LINE VARIO WAVE 42 drainage profile

as a 1.2 m W-shaped, height-adjustable drainage profile that can be variably cut to size, featuring a visible drain slot in a width of 24 mm and a length of 140 mm that can be concealed from view with a removable panel, and including 2 end caps, to be installed in the proper height as part of the covering installation

■ length: 1.2 m

■ length: 1.8 m

**Material:**

- EB = rushed stainless steel 1.4404 (V4A)
- MBW = colour coated aluminium, matte brilliant white
- MGS = aluminium, matte graphite black
- TSGB = aluminium, textured natural beige grey
- TSC = aluminium, textured natural cream
- TSDA = aluminium, textured natural dark anthracite
- TSI = aluminium, textured natural ivory
- TSOB = aluminium, textured natural bronze
- TSG = textured grey
- TSSG = aluminium, textured natural stone grey

. . . to be supplied and professionally installed according to manufacturer's specifications.

Art.-No.: \_\_\_\_\_

Material: \_\_\_\_\_ £/unit

Labour: \_\_\_\_\_ £/unit

Total: \_\_\_\_\_ £/unit



### Accessories:

#### Frame extensions

\_\_\_\_\_ units Schlüter-KERDI-LINE-VARIO DSE as a frame extension set that enables the use of the respective profiles with tiles that are 10 mm thicker, to be supplied and installed

■ for COVE 26 and WAVE 34 drainage profile

■ for WAVE 42 drainage profile

. . . in a sloped screed according to manufacturer's specifications.

Art.-No.: \_\_\_\_\_

Material: \_\_\_\_\_ £/unit

Labour: \_\_\_\_\_ £/unit

Total: \_\_\_\_\_ £/unit

#### Hair trap

\_\_\_\_\_ units Schlüter-KERDI-LINE VARIO S as an optionally available hair trap for the WAVE 42 profile series, which in addition to its primary function also reliably prevents small parts from being flushed down the drain, to be supplied and installed

. . . in a sloped screed according to manufacturer's specifications.

Art.-No.: \_\_\_\_\_

Material: \_\_\_\_\_ £/unit

Labour: \_\_\_\_\_ £/unit

Total: \_\_\_\_\_ £/unit

